

MAINTENANCE-FREE CONSTRUCTION

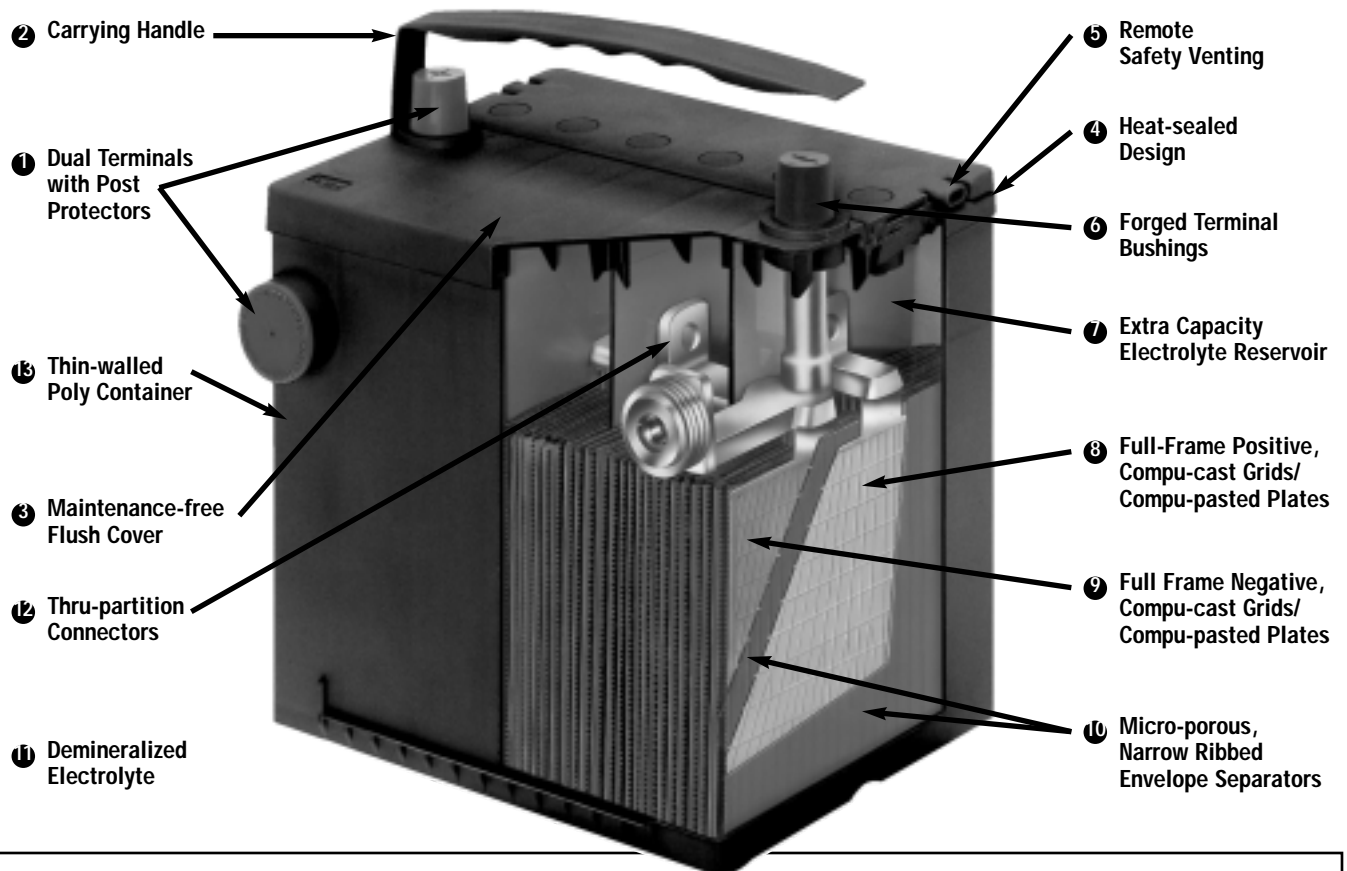

Features and Benefits

- 1 Convenient dual terminal design allows **maximum flexibility** to fit hundreds of different applications.
- 2 Easy grip carrying handle offers **easy installation**.
- 3 Original equipment style flush cover design is truly **maintenance-free**. Fits under O.E. heat shields.
- 4 High-impact cover is heat sealed to the case under extreme pressure. This helps prevent electrolyte leakage, improves reliability and **reduces breakage**.
- 5 Remote safety vents are **flame-retardant**. Keep battery top dry and corrosion-free. Allow remote vent tube installation if required.
- 6 Forged terminal bushings are fused into the cover to provide maximum resistance to acid seepage, corrosion and black posts.
- 7 Large reservoir above the plates provides ample electrolyte reserve for longer **maintenance-free** performance and life.
- 8 Positive center-lug, full-frame, power path grids direct more current to the terminals to deliver **maximum starting power** every time. Calcium-lead alloy **reduces water loss and self discharge**.
- 9 Continuous-cast, full-frame, calcium alloy negative grids enhance efficiency of current flow and resist vibration damage for **trouble-free service**. There are no sharp grid wires to cause shorts.
- 10 Premium narrow-rib, deep-pocket envelope separators virtually **eliminate shorting**. Narrow ribs reduce separator "corrode thru." Deep-pocket envelopes dramatically **improve reliability and extend service life**.
- 11 Specially formulated electrolyte, an exclusive feature, uses demineralized water for significantly reduced water loss and gassing to **increase maintenance-free life**.
- 12 Straight-through-the-partition cell connectors shorten current path while **increasing starting power** and delivering **more power-per-pound**.
- 13 Thin-walled, high-impact polypropylene case **reduces breakage** while creating more room for power-producing plates and acid.
- In addition, a snap-off height adjuster (not pictured) allows installation in short or tall battery applications, for **increased coverage and versatility**.